

— Phase A
 — Phase B
 — Phase C

Waveform: Start of Event

Analysis

Low frequency transients, most likely related to utility switching of capacitor banks, used to regulate voltage or control power factor.

Peak voltage levels are impacted by this very low frequency transient, which could cause damage due to overvoltage.

Event	Date and Time	Type	Severity	Minimum	Maximum	Duration
5	7/10/05 20:05:56	Subcycle	Moderate	-460.5	427.5	1

Technical Analysis

Capacitors are used throughout the electrical distribution system to filter harmonics, stabilize voltage, and correct lagging power factor generated by the more commonly found inductive loads (transformer, motors, etc) used by electricity customers.

At both the utility level as well as the facility level, it is common to switch capacitor banks on and off, related to utility loading. Sometimes these capacitors are switched based on actual load and power factor conditions. In other cases, the capacitors are switched on a timer, at a set time each day or workday.

Voltage transients can result from this switching, dependent upon the size of the capacitor bank, the characteristics of the electrical system, loading, and the phase angle at which the capacitors are applied. The resulting voltage transients can vary widely in terms of frequency, amplitude and duration. In general, lower frequency transients are located at higher voltages / higher power distributions - whereas lower frequency transients are generated closer to the facility.

Even if capacitor banks are not switched, ringing transients can result from step-changes in voltage level, step-changes in loading, and unrelated voltage transients. These transients cannot be confirmed, and the nature and severity of such transients cannot be easily predicted without site-specific experience and/or power monitoring.

It is difficult to filter or attenuate these types of transients; often the only certain solution is a double conversion power conditioner / UPS that is capable of surviving the transients itself.

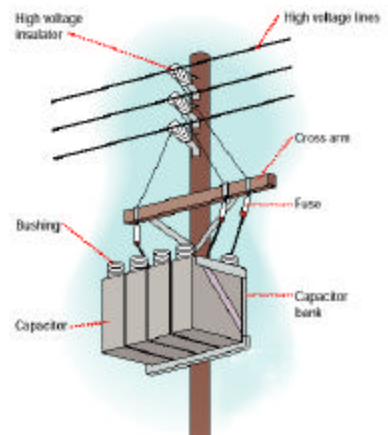
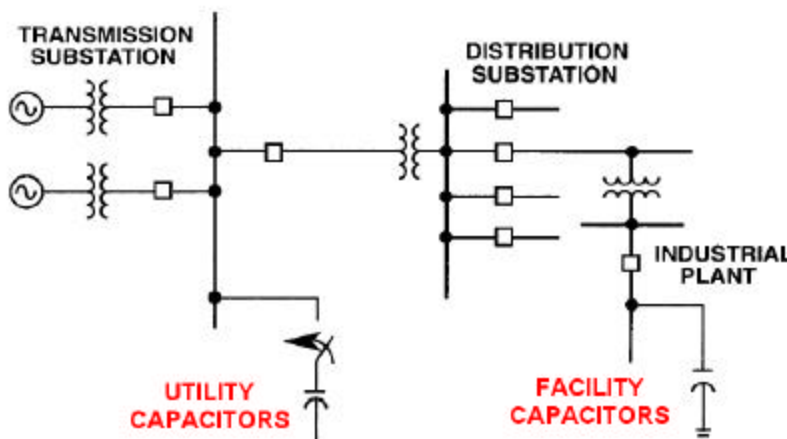

Illustration courtesy Pacific Gas & Electric - www.pge.com